



SECTION 1 – Table of Contents

SECTION 1 – Table of Contents	1
SECTION 1 – Table of Contents	2
SECTION 2 – Executive Summary	3
2.1 – Executive Summary	3
2.1.1 – Overview	3
2.2 – Bliss Clothing Contact Information	3
2.3 – Document Control	3
2.3.1 – Record of Changes	3
SECTION 3 – All about Bliss	4
3.1 – Bliss Defined	4
3.2 – Our Concept	4
3.3 – Our Vision	4
SECTION 4 – Bliss Collection 1	5
4.1 – Collection Overview	5
4.1.1 – Face	5
4.1.2 – Pain	5
4.1.3 – Invisible Gun	5
4.1.4 – Bliss	5
4.1.5 – T-shirt Pattern	6
4.1.6 – A Box full of Bliss	7
4.2 – Collection 1 Gallery	8
SECTION 5 – Bliss Pricings	9
5.1 – International Pricing	9
5.1.1 – Online Pricing	9
5.1.2 – 3 rd Street Promenade in Santa Monica, Los Angeles	9
5.2 – Domestic Pricing	9
5.2.1 – Online Pricing	9

SECTION 2 – Executive Summary

2.1 – Executive Summary

2.1.1 – Overview

This is an introduction document prepared for you to get to know us, Bliss Clothing, better. It describes our concept, vision, internal process, and execution method in full detail.

2.2 – Bliss Clothing Contact Information

Should you have any question about Bliss Clothing, please contact:

Name: Khun Onuma Chintanasatit (นางสาวอรอุมา จินตณสถิตย์)

Tel: 09.138.5715

E-mail: beblissednow@yahoo.com

URL: <http://www.pixelfucker.net/bliss/>

Address: 305/87 Soi Pichai, Dusit, Bangkok, 10300

2.3 – Document Control

2.3.1 – Record of Changes

Date	Author	Version	Change Reference
Feb 23 2003	Bliss Clothing	1.0	No Previous Document

SECTION 3 – All about Bliss

3.1 – Bliss Defined

Designs are everywhere in our life, whether it may be the pen you are holding, a cellular phone you plan on purchasing next week to the very close thing to you, literally, your cloth. Bliss Clothing realizes that there are more to a nicely designed cloth, we believe that clothing can make one feels great. Through great and innovative designs, carefully chosen colors, plus the unsurpassed silkscreen process, a Bliss shirt stands out as one of the best designed t-shirts ever produced.

“Bliss” means the ultimate happiness for a shopper. Bliss means wearers of our products are more than content with what they got. Bliss means the product well worth their money.

Through our extensive research, clothing is one among other products people tend to purchase for themselves. We can conclude that, especially for girls, 60-65 % of clothes are acquired by those who will be wearing them. Hence, the Bliss tagline— “make yourself happy”— truly helps define our branding and identity.

3.2 – Our Concept

It all started with the belief and understanding that clothing is an essential thing to our life. Based on this, we will design and manufacture collections of t-shirt to match our concept. Scheduled to be released 4 times a year, each collection will contain approximately 3-5 different designs to fit sub-concept of particular collection.

Our experienced designers then began with a collection concept, design sketches, adjustments, and eventually evolve into the final designs. In the first collection, we have produced 4 designs defining 4 different types of girl under a concept “Blissful tees”.

3.3 – Our Vision

What sets us apart from the norms? It's simple—t-shirt designs that combine aesthetic beauty through the use of colors, design, and garment. Our products represent a seamless fusion of beautiful design and traditional 100% cotton t-shirt. We believe in the t-shirt that not only uplift the creativity and meet wearers' everyday needs, but also make the wearers proud and happy to own our products.

SECTION 4 – Bliss Collection 1

4.1 – Collection Overview

In the first collection, “Blissful Tees”, we emphasize our brand by developing 4 distinct designs. Each design is an illustration of a girl with a different look, feeling, and attitude.

4.1.1 – Face



Face design represent a simple, quiet, yet internally happy girl. This design brings out minimalism and utilizes only few colors to convey “Blissfulness”

The primary colors of this design are yellow, dark brown, and blue.

4.1.2 – Pain



Pain design is suitable for a girl with more than ordinary not only just her look but her expression to the world. The coloring and silk-screening of this design were carefully chosen and monitored to bring out the true feeling of this design.

The primary colors of this design are dark red and reddish skin tone.

4.1.3 – Invisible Gun



Mystery is what the main theme for this design. This type of girls causes others to be even more curious about them. The design leaves the unseen areas to be imagined by viewers.

The primary colors of this design are skin tone color and gray.

4.1.4 – Bliss



Cheerful girl with an unforgettable smile and attitude, Bliss design is perfect for those who always happy and not afraid to show to the world how she feels.

The primary colors of this design are skin tone, red, and brown.

4.1.5 – T-shirt Pattern

All Bliss T-shirts are made from 100% cotton. The back of all t-shirt has Bliss insignia silk screened on.

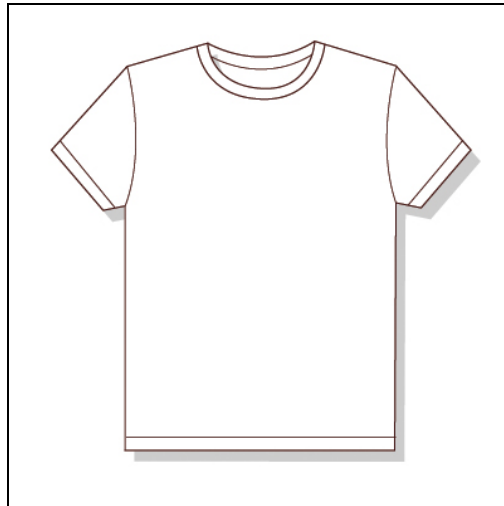

Front

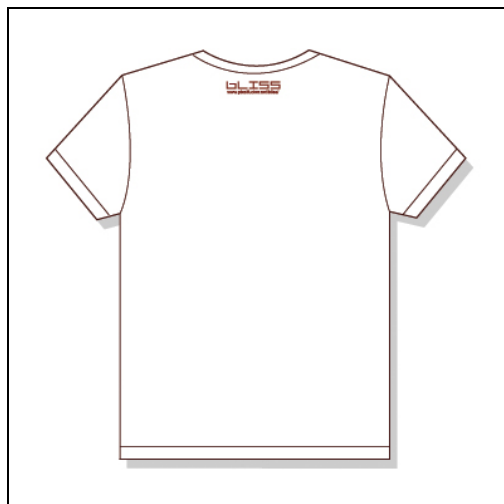

Back

4.1.6 – A Box full of Bliss

A Bliss Collection 1 package contains the following items (as seen in the diagram below):

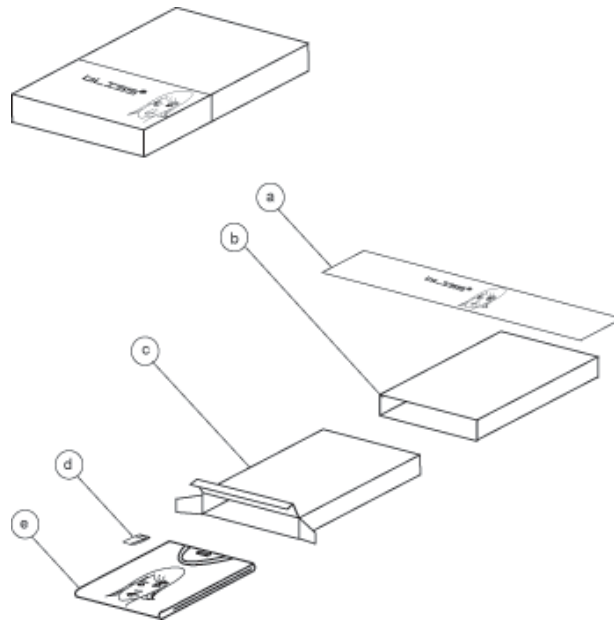

- a. Semi Transparent Bliss paper.
- b. Outer brown box made of 100% recycled paper.
- c. Inner box which contains the main product within.
- d. Bliss Fortune Candy – one bite of sweet stuff and a one liner full of useful thought.
- e. The Bliss Tee – the never ending wearable happiness.

4.2 – Collection 1 Gallery

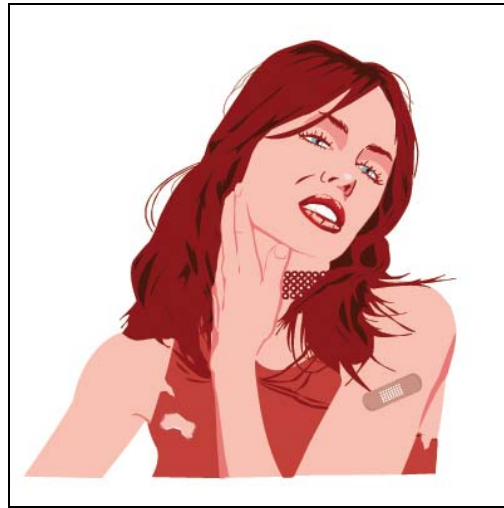
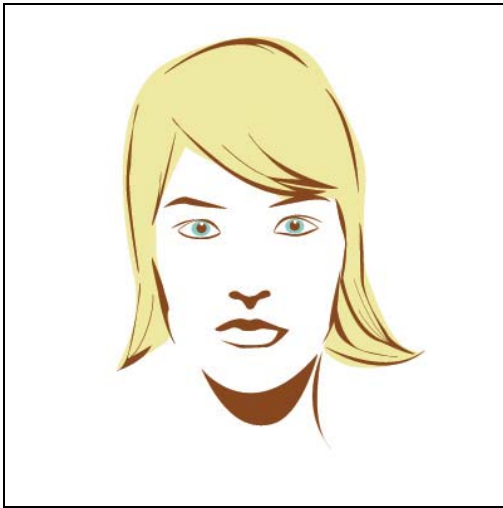

SECTION 5 – Bliss Pricings

5.1 – International Pricing

5.1.1 – Online Pricing

Bliss T-shirts are available to be ordered online at <http://www.pixelfucker.net/bliss/>. (Also available in Thai at http://www.pixelfucker.net/bliss/index_th.shtml) The standard pricing is US\$ 19.99 + shipping and handling fee (no more than US\$ 12).

5.1.2 – 3rd Street Promenade in Santa Monica, Los Angeles

The retail pricing of US\$19.99 per shirt is also available in the traditional shop and go market near Santa Monica Beach, California.

5.2 – Domestic Pricing

5.2.1 – Online Pricing

Bliss T-shirts are available to be ordered online at http://www.pixelfucker.net/bliss/index_th.shtml. (Also available in English at <http://www.pixelfucker.net/bliss/>) The standard pricing is 359 Thai Baht + shipping and handling fee.